

Weights

Operating weight	6130 kg
Additional weight for segmented tracks	243 kg
Additional weight for cab with HVAC	19 kg
Additional weight for steel tracks	125 kg
Additional weight for long dipperstick	21 kg
Additional weight for counter weight	239 kg
Ground pressure with rubber tracks	31.70 kPa

Engine

Make / model	Bobcat 2.4L, 97/68 EC Stage V
Fuel	Diesel
Number of cylinders	4
Displacement	2392 cm ³
Maximum NET power (ISO 9249)	41.0 kW
Maximum NET torque (ISO 9249)	190.0 Nm

Hydraulic System

Pump type	Single outlet variable displacement piston pump with gear pumps
Pump capacity	138.50 L/min
System relief pressure for slew circuit	250.00 bar
Auxiliary (AUX1) flow	85.70 L/min
Auxiliary (AUX2) flow	45.40 L/min

Performance

Digging force, dipperstick (ISO 6015)	33472 N
Digging force, long dipperstick (ISO 6015)	28405 N
Digging force, bucket (ISO 6015)	47841 N
Travel speed, low range	2.9 km/h
Travel speed, high range	4.9 km/h

Slew System

Boom swing, left	75.0°
Boom swing, right	50.0°
Slew rate	8.9 RPM

Fluid Capacities

Cooling system	9.50 L
Engine lubrication plus oil filter	9.80 L
Fuel reservoir	72.00 L
Hydraulic reservoir	15.10 L
Hydraulic system	60.00 L

Environmental

Noise level LpA(EU Directive 2006/42/EC)	77 dB(A)
Noise level LWA(EU Directive 2000/14/EC)	97 dB(A)
Whole body vibration (ISO 2631-1)	0.35 ms ⁻²
Hand-arm vibration (ISO 5349-1)	0.94 ms ⁻²

Standard Features

1960 mm dozer blade	Full fuel warning alarm
400 mm rubber track	Horn
Deluxe display with integrated keyless	Hydraulic joystick controls
Auto idle	Proportional fingertip auxiliary and boom swing offset
Adjustable double acting auxiliary hydraulic (AUX1) with QC on ARM	Retractable seat belt
Battery disconnect switch	Selectable auxiliary hydraulic flow
Blade float feature	Suspension seat with high back
Clamp ready	Storage compartment
Control console locks	Tool box
Cupholders	TOPS/ROPS/FOPS cab * 1
Dual Direction Detent	Two-speed travel with Auto shift
Dual flanged rollers	Upper structure tie down
Engine/hydraulic monitor with shutdown	LED work lights (boom + 2x canopy)
Foldable and ergonomic pedals	Warranty: 24 months, 2000 hours (whichever occurs first)

1. Roll Over Protective Structure (ROPS) – Meets requirements of ISO 3471. Tip Over Protective Structure (TOPS) – Meets requirements of ISO 12117. Falling Object Protective Structure (FOPS) – Meets requirements of ISO 3449.

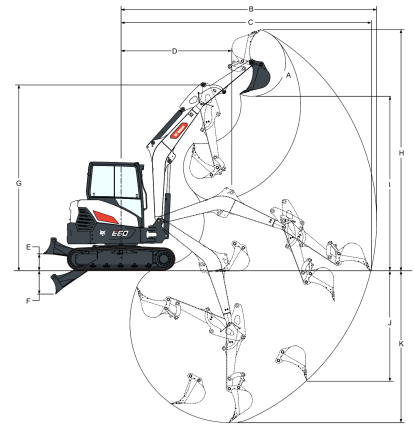
Working Range

(A)	186.0°	(G)	4390.0 mm
(B)	5958.0 mm	(H)	5630.0 mm
(C)	6336.0 mm	(H*)	5885.0 mm
(C*)	5822.0 mm	(I)	4076.0 mm
(D)	6209.0 mm	(I*)	4331.0 mm
(D*)	2436.0 mm	(J)	2561.0 mm
(E)	2533.0 mm	(J)	2941.0 mm
(F)	390.0 mm	(K)	3537.0 mm
(F)	547.0 mm	(K*)	3937.0 mm

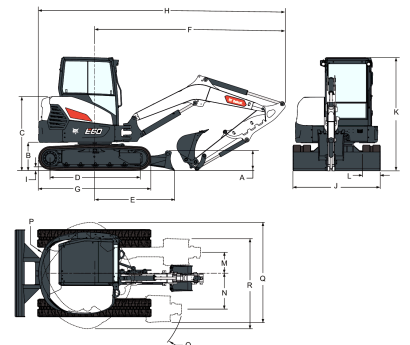
Dimensions

(A)	422.0 mm	(J)	1959.0 mm
(B)	637.0 mm	(K)	2551.0 mm
(C)	1849.0 mm	(L)	400.0 mm
(D)	2004.0 mm	(M)	473.0 mm
(E)	1784.0 mm	(N)	730.0 mm
(F)	4278.0 mm	(O)	1965.0 mm
(G)	2523.0 mm	(P)	1265.0 mm
(H)	5543.0 mm	(P*)	1335.0 mm
(H*)	5541.0 mm	(Q)	2245.0 mm
(I)	24.0 mm	(R)	2227.0 mm

Options

Air conditioning (Cab with HVAC)	AM/FM MP3 stereo radio with Bluetooth
Auto Air conditioning (Cab with Auto HVAC)	FOGS kit (Overhead guard)
7" touch screen	Lifting chain kit
Keyless ignition	Travel motion alarm
Long dipperstick	400 mm Steel tracks
Add-on counterweight	400 mm Segmented tracks
Machine IQ (telematic)	Fuel refill pump
2nd Auxiliary hydraulics	Beacon kit
Case drain line	Left and right mirror kit
Clamp with AUX1 valve	Fire extinguisher
Tilt coupler lines (AUX4)	Additional LED work light kit
Hydraulic coupler lines (AUX5)	Rubber bolt-on pads for steel tracks
Deluxe textile suspension seat	Special applications kit (Front windscreen protection)

Heated Deluxe textile
suspension seat with head
rest

Boom safety valve with
overload warning
Boom & arm safety valves
with overload warning

Bucket valves (AUX3) kit
Depth Check kit