

**Engine**

Engine type	3 cylinder, water cooled, 4 cycle, Indirect Injection (IDI)
Fuel	Diesel
Displacement	1.00 L
Max Torque	57.0 Nm
Gross Power (ECE-R120)	24.5 HP
Net Power	23.0 HP
Rated revolution	3200.0 RPM
Alternator	12V 50A
Air Cleaner	Dry type, replaceable
Fuel tank	25.50 L

**Drive Train**

Transmission	HST, 2 range
Shuttle Type	Hydrostatic Drive
Max. Travelling Speed Forward	16.5 km/h
Max. Travelling Speed Reverse	11.2 km/h
Steering	Hydrostatic Power Steering
Turning radius(w/brake)	2540.0 mm
Brake type	Wet disc type
Mechanical differential lock	Rear Std.

**Hydraulic System**

Implement Pump	18.70 L/min
Power steering pump	7.00 L/min
Total hydraulic flow	25.70 L/min
No. of Std. remote valve's ports (Rear)	Std. (2 port)

**Hitch**

3-point lift control type	Position
3-point hitch type	Category 1
Lower Link type	Ball
Lift capacity at lift point	715 kg
Lift capacity at 610 mm (24 in.) behind lift point	318 kg

**PTO**

Max PTO Power	18.5 HP
Rear PTO type	Independent
Rear PTO speed	540.0 RPM
Mid PTO speed	2200.0 RPM

**Tires**

Turf tires	Front: 18x8.5-10 R3 / Rear: 26x12.00-12 R3
Industrial Tires	Front: 18x8.5-10 R4 / Rear: 26x12.00-12 R4

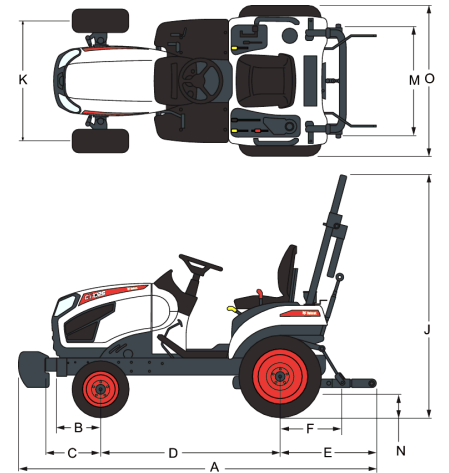
**Dimensions**

Values are measured on Turf Tires

(A)	2882.0 mm	(J)	2284.8 mm
(B)	341.0 mm	(K)	939.0 mm
(C)	433.0 mm	(M)	864.0 mm
(D)	1400.0 mm	(N)	170.8 mm
(E)	748.0 mm	(O)	1185.0 mm
(F)	347.0 mm		

**Weights**

Weight with ROPS	719 kg
------------------	--------

**Standard Features**

4 Wheel Drive	Toolbox
Rear View Mirror	Front Hitch
Battery	Hydrostatic Power Steering
Horn	Rear folding ROPS
7 Pin Socket	Rear PTO, Independent
OPC	12V Aux
Cup holder	Beacon Ready Wiring
SMV sign	Engine Hood, one piece
PTO Cover	Vinyl Suspension Seat,
HST Cruise	w/retractable seat belt