

**Performance**

Bucket capacity	0.8 m <sup>3</sup>
Bucket range	0.6 - 1.5 m <sup>3</sup>
Tipping load bucket, straight (ISO 14397-1)	3964 kg
Tipping load bucket, articulated at 40° (ISO 14397-1)	3339 kg
Tipping load forks, straight (ISO 14397-1)	3011 kg
Tipping load forks, articulated at 40° (ISO 14397-1)	2619 kg
Lift breakout force (ISO 14397-2)	4978 kg
Lift capacity (ISO 14397-2)	2312 kg
Maximum travel speed — Range I	25.0 km/h
Maximum travel speed — Range II	40.0 km/h

**Engine**

Model	2.4L V2 BOBCAT ENGINE
Compliancy	STAGE V
Cooling	Liquid
Fuel	Diesel
Fuel Tank	78.80 L
Power at 2600 RPM (ISO 14396):	55.2 kW

**Weights**

Operating weight, standard (ISO 6016)	5376 kg
Shipping weight, standard (ISO 6016)	4896 kg
Max. static axle load	9000 kg
Max. dynamic axle load	5500 kg

**Hydraulic System**

Control valve	3 spool (optionally 4) - parallel series type - open center
System Relief @ Quick Couplers - High Flow (Option)	22.5 MPa
System Relief @ Quick Couplers	20.5 MPa
Hydraulic Tank	27.20 L
Auxiliary Std Flow	75.40 L/min
Auxiliary High Flow	103.50 L/min

**Drive System**

Main Drive	Proportionally regulated hydrostatic motor
Transmission	Hydrostatic with electronic regulation

**Controls**

Vehicle steering	Machine articulation via hydraulic steering with steering wheel
Travel Direction	Travel direction switch (F-N-R) on joysticks. Drive pedal in work and travel mode.
Machine hydraulics	Dual axis joystick for lift, tilt and auxiliary
Vehicle braking	Combination of integrated 6 wet brake disk in rear axle with hydrostatic braking effect provision

**Environmental**

Noise level LpA(EU Directive 2000/14/EC)	100 dB(A)
Noise level LWA(at operator's ear)	77 dB(A)
Whole body vibration below	0.63 ms <sup>-2</sup>
Hand-arm vibration below	1.31 ms <sup>-2</sup>

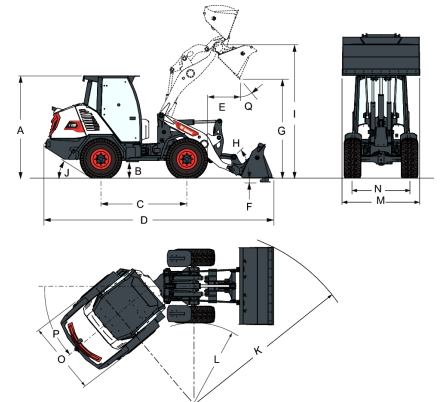
**Dimensions**

(A)	2522.7 mm	(J)	33.3°
(B)	452.0 mm	(K)	4280.4 mm
(C)	2100.0 mm	(L)	1985.6 mm
(D)	5433.6 mm	(M)	1900.0 mm
(E)	660.5 mm	(N)	1393.0 mm
(F)	75.0 mm	(O)	1800.0 mm
(G)	2532.5 mm	(P)	40.0°
(I)	3275.0 mm	(Q)	45.0°

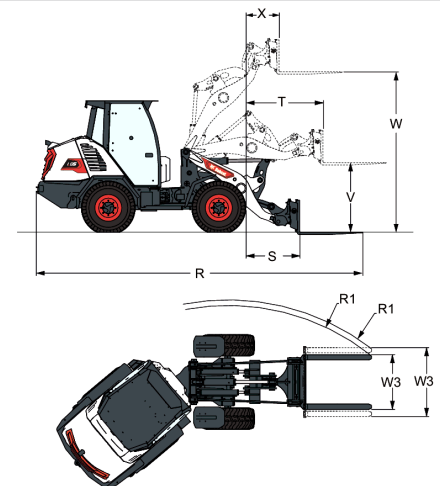
**Dimensions - Pallet fork**

(R)	5959.1 mm	(V)	1399.0 mm
(R1)	4262 - 4472.6 mm	(W)	3125.0 mm
(S)	750.1 mm	(W3)	773.6 - 1313.6 mm
(T)	1252.2 mm	(X)	416.4 mm